



TESLA



HIGH POWER WALL CONNECTOR (HPWC)
INSTALLATION MANUAL

INFORMATION ABOUT YOUR MODEL S IS AVAILABLE AT:

www.teslamotors.com/mytesla

To contact Tesla, call 1-877-79TESLA (1-877-798-3752)

FCC DECLARATION OF CONFORMITY

This device complies with Part 15 of the FCC rules. Operation is subject to the following two conditions: (1) This device may not cause harmful interference, and (2) this device must accept any interference received, including interference that may cause undesired operation.

Radio and television interference

The equipment described in this manual has been designed to protect against Radio Frequency Interference (RFI). However, there are some instances where high powered radio signals or nearby RF-producing equipment (such as digital phones, RF communications equipment, etc.) could affect operations.

If interference to your High Power Wall Connector is suspected, relocate or turn off nearby electrical appliances during charging, before contacting Tesla for assistance.

Important!

Changes or modifications to this product not authorized by Tesla could void the FCC compliance.

PRODUCT SPECIFICATIONS

All specifications and descriptions contained in this document are verified to be accurate at the time of printing. However, because continuous improvement is a goal at Tesla, we reserve the right to make product modifications at any time.

ERRORS OR OMISSIONS

To communicate any inaccuracies or omissions in this manual, please send an email to: ownersmanualfeedback@teslamotors.com.

©2012-2014 TESLA MOTORS, INC. All rights reserved.

All information in this document and all MODEL S® software is subject to copyright and other intellectual property rights of Tesla Motors, Inc. and its licensors. This material may not be modified, reproduced or copied, in whole or in part, without the prior written permission of Tesla Motors, Inc. and its licensors. Additional information is available upon request. The following are trademarks or registered trademarks of Tesla Motors, Inc. in the United States and other countries:

TESLA

TESLA MOTORS

TESLA
ROADSTER

TESLA



MODEL S

All other trademarks contained in this document are the property of their respective owners and their use herein does not imply sponsorship or endorsement of their products or services. The unauthorized use of any trademark displayed in this document or on the vehicle is strictly prohibited.

TABLE OF CONTENTS



IMPORTANT !

READ THIS ENTIRE DOCUMENT BEFORE INSTALLING OR USING THE HIGH POWER WALL CONNECTOR. FAILURE TO DO SO OR TO FOLLOW ANY OF THE INSTRUCTIONS AND WARNINGS IN THIS DOCUMENT CAN RESULT IN FIRE, ELECTRICAL SHOCK, SERIOUS INJURY OR DEATH.

THE HIGH POWER WALL CONNECTOR MUST BE INSTALLED BY A QUALIFIED ELECTRICIAN, AND IN ACCORDANCE WITH LOCAL ELECTRICAL CODES AND ORDINANCES.

Safety Information	1
Specifications.....	2
Features	3
Service Wiring - North America	4
Service Wiring - Europe.....	6
Circuit Breaker.....	7
Installation Overview	8
Step One - Check Box Contents	9
Step Two - Install Wall Bracket	10
Step Three - Prepare for Installation	11
Step Four - Mount on Wall	12
Step Five - Connect Wiring.....	13
Step Six - Confirm a Successful Installation	14
Step Seven - Set Operating Current.....	15
Step Eight - Secure Cover and Power Up	16
Step Nine - Install Cable Organizer	17
Troubleshooting.....	18
Maintenance and Repair.....	19
Connector Limited Warranty.....	20



SAVE THESE IMPORTANT SAFETY INSTRUCTIONS

This document contains important instructions and warnings that must be followed when installing and maintaining the High Power Wall Connector.



WARNINGS

The High Power Wall Connector must be grounded through a permanent wiring system or an equipment grounding conductor.

Do not install or use the High Power Wall Connector near flammable, explosive, harsh, or combustible materials, chemicals, or vapors.

Turn off input power at the circuit breaker before installing or cleaning the High Power Wall Connector.

Use the High Power Wall Connector only within the specified operating parameters.

The High Power Wall Connector is designed only for charging a Tesla vehicle (excluding Tesla Roadster). Do not use it for any other purpose or with any other vehicle or object.

Stop using and do not use the High Power Wall Connector if it is defective, appears cracked, frayed, broken, or otherwise damaged, or fails to operate.

Do not attempt to open, disassemble, repair, tamper with, or modify the High Power Wall Connector. The High Power Wall Connector is not user serviceable. Contact Tesla for any repairs.

Do not use the High Power Wall Connector when you, the vehicle, or the High Power Wall Connector is exposed to severe rain, snow, electrical storm, or other inclement weather.

When transporting the High Power Wall Connector, handle with care. Do not subject it to strong force or impact or pull, twist, tangle, drag, or step on the High Power Wall Connector, to prevent damage to it or any components.

Protect the High Power Wall Connector from moisture, water, liquid, and foreign objects at all times. If any exist or appear to have entered, damaged, or corroded the High Power Wall Connector, do not use the High Power Wall Connector.

Do not touch the High Power Wall Connector's end terminals with sharp metallic objects, such as wire, tools, or needles.

Do not forcefully fold any part of the High Power Wall Connector or damage it with sharp objects.

Do not insert foreign objects into any part of the High Power Wall Connector.

Do not use the High Power Wall Connector when a vehicle cover is on the vehicle.

Use of the High Power Wall Connector may affect or impair the operation of any medical or implantable electronic devices, such as an implantable cardiac pacemaker or an implantable cardioverter defibrillator. Check with the electronic device manufacturer concerning the effects that charging may have on such electronic devices before using the High Power Wall Connector.



CAUTIONS

Incorrect installation and testing of the High Power Wall Connector could potentially damage either the vehicle's Battery and/or the High Power Wall Connector itself. Any resulting damage is excluded from the warranty for both the vehicle and the High Power Wall Connector.

Do not operate the High Power Wall Connector in temperatures outside its operating range of -22°F to 113°F (-30°C to +45°C).

Ensure that the charge station's supply cable is positioned so it will not be stepped on, tripped over, or subjected to damage or stress.

Do not use cleaning solvents to clean any of the High Power Wall Connector's components. The outside of the High Power Wall Connector, the charging cable, and the connector end of the charging cable should be periodically wiped with a clean dry cloth to remove accumulation of dirt and dust.

Be careful not to damage the circuit board when removing the power entry knock-out.



Specifications

The maximum rating for the High Power Wall Connector is 20 kW or 80 amps at 240 volts. Your vehicle can charge from 200 to 240 volts.

	120V ABOVE GROUND (common in North America)	230V ABOVE GROUND (common in Europe, Asia, and Australia)
Voltage and Wiring	240V AC single-phase: L1, L2, and safety ground 208V AC 3-phase, Wye-connected: Any 2 phases, and safety ground. 240V AC 3-phase, delta-connected: With center tap on one leg, use only the two phases on either side of the center tap. The two phases must both measure 120V AC to ground. Do not use the third leg (208V “stinger”).	230V AC single-phase: LINE, NEUTRAL, and EARTH.
Current	Maximum 100A circuit breaker. The maximum current for charging the vehicle is 80A or 20 kW. At 240V, this is 19 kW maximum.	Maximum 100A circuit breaker. The maximum current for charging the vehicle is 80A or 20 kW. At 230V, this is 18 kW maximum.
Frequency	60 Hz	50-60 Hz
Cable Length	Approximately 25' (7.6 m)	
Bracket Dimensions	Height: 15" (382 mm) Width: 6.22" (158.2 mm) Depth: 3.7" (96 mm)	
Weight (including bracket)	20 lbs (9 kg)	
Operating Temperature	-22°F to 113°F -30°C to 45°C	
Storage Temperature	-58°F to 185°F -50°C to 85°C	
Enclosure Rating	Type 3R	IP 44
Agency Approvals	UL listed under file number E351001, FCC Part 15	CE



OPTIONAL CIRCUIT RATINGS

For the fastest charging, using a circuit breaker rated for 100 amps is recommended. In certain home or office locations, this level of power isn't readily available. Therefore, you can adjust the current setting on the High Power Wall Connector for 40 to 100 amp breakers (see page 15).

SELF-MONITORING AND RECOVERY

The High Power Wall Connector has a ground monitoring circuit that continuously checks for the presence of a safe ground connection and automatically recovers from faults. Manual testing and resetting is not required.

Temporary problems such as ground faults or utility power surges are overcome automatically. If a GFCI fault occurs that interrupts charging, the High Power Wall Connector automatically tries to clear the fault and re-attempt charging.

If the problem is immediately sensed a second time, the High Power Wall Connector waits 15 minutes before trying to charge. This process repeats eight times and if all attempts are unsuccessful, power is removed and no further attempts are made. In this case, a red error light lights up on the front panel (refer to the troubleshooting table on page 18). It is recommended that when you see a red error light, you power off the High Power Wall Connector and then power it back on again.

POWER OUTAGES

If a power outage occurs, the High Power Wall Connector automatically resumes charging when power is restored. If the charging cable is plugged into the vehicle when power is restored, the lights blink and the unit does not energize the charging cable for approximately 15 seconds to 3 minutes. This prevents the utility grid from experiencing a large surge when power is restored, allowing vehicles to begin drawing current at random times, rather than all at once.

120V ABOVE GROUND

! **WARNING:** The High Power Wall Connector is a single-phase device. Do not connect all 3 phases of a 3-phase feed.

! **WARNING:** Before installing the High Power Wall Connector, identify the type of utility service connection available on site. If you are unsure about the type of connection available at the service panel, consult the local utility company, or contact Tesla for assistance.

! **CAUTION:** The two phases used must each measure 120V to neutral. earth ground must be connected to neutral at only one point, usually at the breaker panel.

! **CAUTION:** If a 240V 3-phase feed is from a Delta-connected secondary, the leg used must have a center tap. This center tap must be grounded. Only the two phases on either side of the center-tapped leg can be used.

For most branch circuits of 100A, use 3 AWG (26.7 mm²), 167°F (75°C) copper wire. Ground wiring can be a maximum of 4 AWG. If your ground wiring does not fit into the bus, use a wire nut or other suitable connection method. For installations less than 100A, use conductors that are sized according to local electrical codes.

Run 1" (25 mm) conduit on the left side of a wall stud. The conduit fits into the opening on either the back or the left side of the High Power Wall Connector as described on page 11.

The service connections described next are primarily used in North America. For service connections used in Europe and Australia (sometimes known as "TT Power Grid"), see page 6.

Only three wires are connected, but care must be taken that the service transformer secondary connection is definitely known, and that the three wires from the main circuit breaker panel are correctly connected and labeled. The illustrations shown are the most commonly used wiring formats.

NOTE: The L1, L2, and ground outputs labeled on the illustrations correspond to the inputs on the High Power Wall Connector.

Ground Connection

Always connect the neutral at the service to earth ground. Ground fault protection is not possible unless the neutral (center tap on the service transformer) is connected to an earth ground.

If ground is not provided by the electrical service, you must install a grounding stake nearby. The grounding stake must be connected to the ground bar in the main breaker panel, and neutral connected to ground at that point.

! **WARNING:** Follow local electrical codes when installing the grounding stake.

220/240V Single Phase

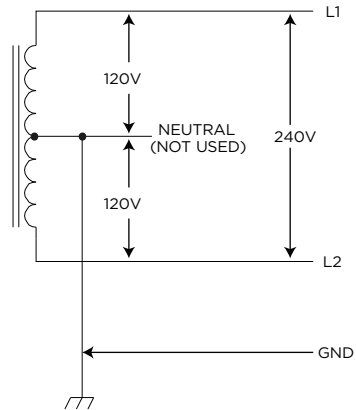

NOTE: Illustrations in this document are for demonstration purposes only.



208V 3-Phase Wye-Connected

With a Wye-connected secondary, any two of the legs can be used to provide 208V to the High Power Wall Connector. For example, L1 and L2, or L1 and L3, or L2 and L3. The two used phases must each measure 120V to neutral.

NOTE: A current-carrying neutral is not required.

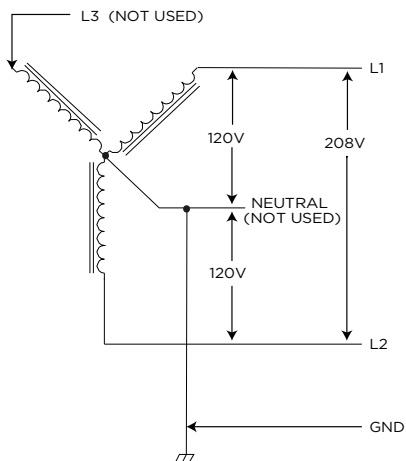

CAUTION: The unused leg (L3 in the illustration) must remain open. Do not connect to a neutral bar, or to ground.

CAUTION: The center point of the 3 phases (normally used as neutral) must be grounded to earth at only one point. This is usually at the breaker panel.

240V 3-Phase Delta-Connected

With the delta connection, one leg must be center tapped, and only the two phases on either side of the center tap can be used. The two used phases must each measure 120V to neutral.

Consult the transformer manufacturer's literature to verify that the single leg can supply the required power.

NOTE: The High Power Wall Connector's contactor closes only if it detects the presence of a Ground wire connected to a neutral point on the transformer secondary.

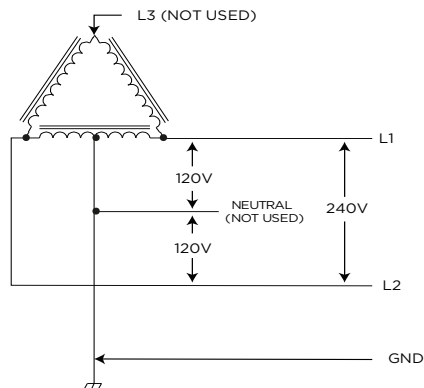

CAUTION: The third line (L3 in the illustration) of the delta is 208V, with respect to neutral, and is sometimes referred to as a "stinger." Do not use this third line.

CAUTION: Do not use a 3-phase delta-connected transformer secondary without a center tap on one leg. No "neutral" point is available for the required ground connection.



230V ABOVE GROUND

! WARNING: The High Power Wall Connector is a single-phase device. Do not connect all 3 phases of a 3-phase feed.

! WARNING: Before installing the High Power Wall Connector, identify the type of utility service connection available on site. If you are unsure about the type of connection available at the service panel, consult the local utility company, or contact Tesla for assistance.

! CAUTION: The line connection must measure 230V RMS to neutral. earth must also be connected to the High Power Wall Connector.

For most branch circuits of 100A, use 3 AWG (26.7 mm²), 75°C (167°F) copper wire. For installations less than 100A, use conductors that are sized according to local electrical codes. Ground wiring can be a maximum of 4 AWG. If your ground wiring does not fit into the bus, use a wire nut or other suitable connection method.

Run 25 mm (1") conduit on the left side of a wall stud. The conduit fits into the opening on either the back or the left side of the High Power Wall Connector as described on page 11.

The service connections described below are primarily used in Europe and Australia (sometimes known as "TT Power Grid"). For service connections used in North America, see page 4.

When connecting the line and neutral wires, care must be taken that the service transformer secondary connection is definitely known, and the wires from the main circuit breaker panel are correctly connected and labeled. The illustrations provided show the most commonly used wiring format in Europe.

NOTE: The line, neutral, and earth outputs labeled on the illustrations correspond to the inputs on the High Power Wall Connector.

Ground (Earth) Connection

Always connect the neutral line at the service panel to earth. Ground fault protection is not possible unless the neutral line is connected to earth.

If an earth connection is not available, you must install a grounding stake nearby. The grounding stake must be connected to the ground bar in the main breaker panel, and neutral connected to earth at that point.

! WARNING: Follow local electrical codes when installing the grounding stake.

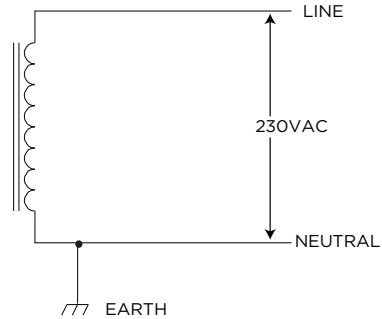



NOTE: Refer to the National Electric Code (NEC) and local electrical codes when installing the High Power Wall Connector. If in doubt, check with your local building electrical inspector.

To determine the type of electrical breaker you need, examine the distribution panel/circuit breaker box to identify the amperage available at the installation site.

The High Power Wall Connector has internal DIP switches that allow you to adjust its operating current based on the type of circuit breaker being used (40 to 100 amps):

Circuit Breaker Rating (Amps)	Maximum Current Supplied to Vehicle (Amps)
40	32
50	40
60	48
70	56
80	64
90	72
100	80

To install a breaker:

- Turn off AC power to the distribution panel/circuit breaker box.
- Install the circuit breaker appropriate for your installation site and vehicle charging requirements.
- Run the L1, L2 and Ground wires from the distribution panel/circuit breaker box to the location where you are installing the High Power Wall Connector. Always run wiring to the left side of a wall stud.



TOOLS REQUIRED

Before installing the High Power Wall Connector, ensure you have the following tools:

- Pencil or marker
- Drill and 9/32" and 3/16" drill bits
- T20 torx driver
- Hole saw (1 1/4" / 32 mm)
- Sharp knife or razor
- Phillips screwdriver
- Ratchet wrench with 8 mm and 17 mm sockets, and a 2" (minimum) extension
- Voltmeter or digital multimeter (to measure AC power at the site)

OVERVIEW OF STEPS

After running service wiring to the desired installation location using 1" (25 mm) conduit, (see pages 4 through 6), and installing the appropriate circuit breaker (see page 7), **TURN OFF THE POWER SUPPLY**. Then follow these steps to install the High Power Wall Connector:

- 1** Check box contents (see page 9)
- 2** Install wall bracket (see page 10)
- 3** Prepare for installation (see page 11)
- 4** Mount on wall (see page 12)
- 5** Connect wiring (see page 13)
- 6** Confirm a successful installation (see page 14)
- 7** Set operating current (see page 15)
- 8** Secure cover and power up (see page 16)
- 9** Install Cable Organizer (see page 17)

Step One - Check Box Contents



In addition to this Installation Guide, the shipping box contains the following components. If any components are damaged or missing, contact Tesla.

High Power Wall Connector assembly

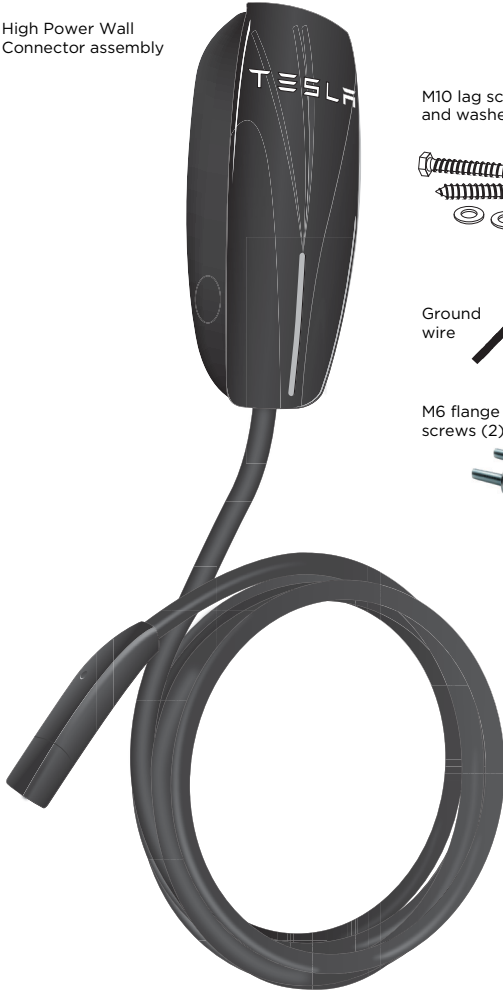

Mounting bracket

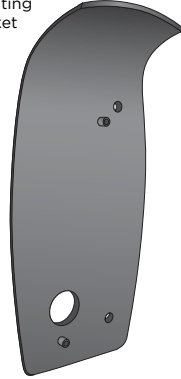

M10 lag screws and washers (2)

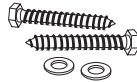

Ground wire



M6 flange screws (2)



Cable Organizer



Cable Organizer Bracket



Cable Organizer Screws, Anchors, and Washers (2each)





Step Two - Install Wall Bracket

You can run 1" (25 mm) conduit into either the back or the left side of the High Power Wall Connector's main enclosure. Regardless of the conduit opening you use, always run the conduit on the left side of a wall stud. Refer to the illustration below for dimensions.

When determining where to mount the High Power Wall Connector, keep in mind that its 25' (7.6 m) charge cable should easily reach the vehicle's charging port without straining the connections at either end.

- 1 Use the mounting bracket as a guide to mark the location on the wall for the two mounting screws.
 - Space the holes exactly 8 7/16" (214 mm) apart.

- The height of the bracket should ensure that the charging connector is located at a maximum of 48" from floor level.* The minimum height is 18" (46 cm) if mounting indoors, and 24" (61 cm) if mounting outdoors.

- 2 Drill two 3/8" (7.1 mm) holes in the wall.
- 3 Attach the wall bracket using fasteners appropriate for the type of wall material. Use the supplied lag screws and washers only if mounting to a solid wooden wall stud. If mounting to another type of wall (hollow, masonry, etc.), use fasteners that are long enough to securely anchor the High Power Wall Connector and that can support at least 80 pounds (36 kg).

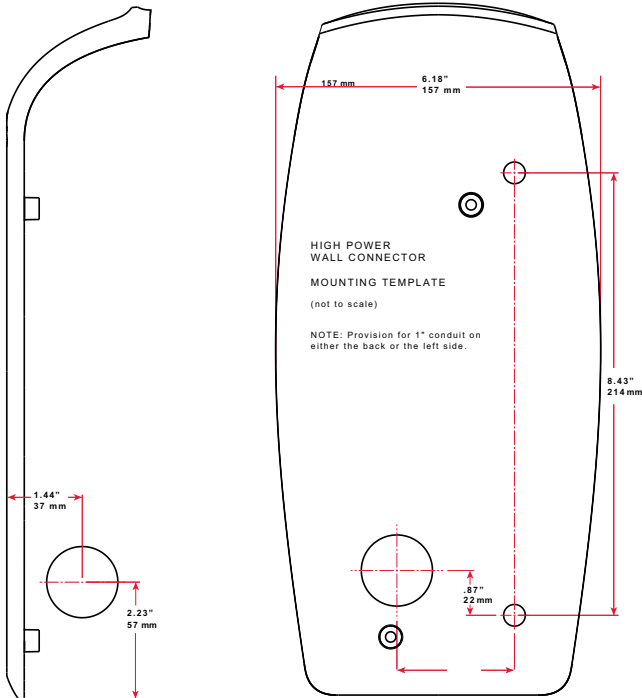

 *CAUTION: If installing in a public location, consider laws and regulations that accommodate persons with disabilities (such as the ADA - American Disabilities Act).

Step Three - Prepare for Installation



- 1 Using a T20 Torx driver, remove the two security screws from the bottom of the High Power Wall Connector.



- 2 Release the front cover by pulling it towards you far enough to disconnect the ribbon cable. Disconnect the ribbon cable from inside the main enclosure to fully release the front cover.

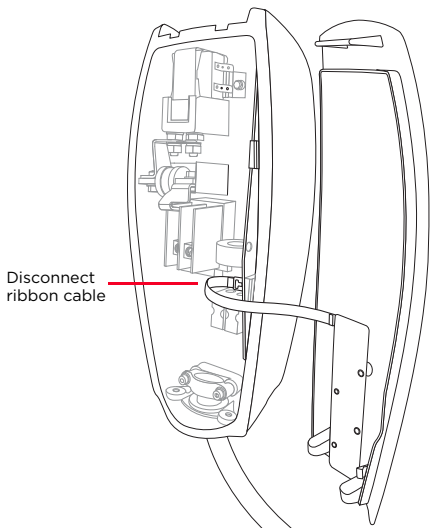

CAUTION: When removing the front cover, do not damage the ribbon cable. Disconnect the ribbon cable before fully releasing the front cover.

- 3 Disconnect the ground wire from the

terminal block and push it out of the way to avoid damaging it when completing the next step.

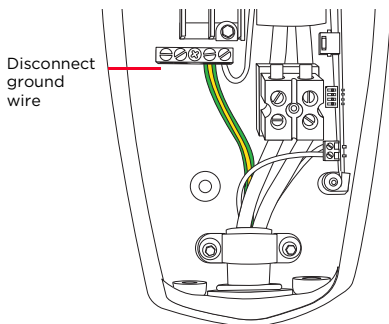

- 4 Use a 1 1/4" (32 mm) hole saw to remove the power entry knock-out from either the side or back of the connector.

CAUTION: When using the hole saw, do not damage internal components.

If using the side knock-out, center the hole saw at the indented hole and drill through all layers. After drilling, use a sharp knife or razor to cut and remove the rubber molding, as indicated by the indentations in the rubber.

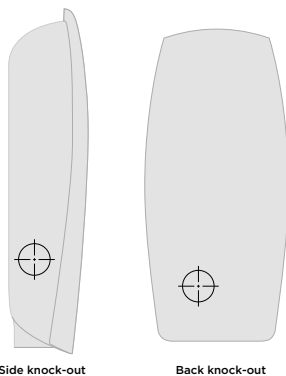

NOTE: Use the back knock-out when mounting to a pedestal or when running wires from behind a wall.

- 5 Reconnect the ground wire to the terminal block.



Step Four - Mount on Wall

- 1 Position the connector over the bolts on the mounting bracket as shown below.
- 2 Attach the ground wire, as shown below.
- 3 Use the supplied flange screws to fasten the connector onto the bracket. Use a ratchet wrench and 8 mm socket to tighten until snugly fitted.

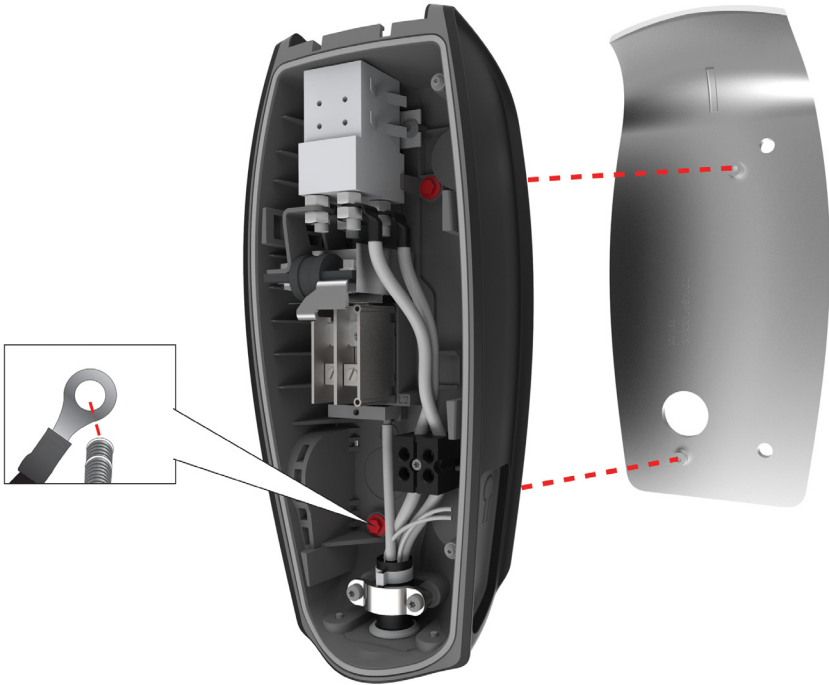



NOTE: For most branch circuits of 100A, use 3 AWG (26.7 mm2), 75°C (167°F) copper wire. For installations less than 100A, use conductors that are sized according to local electrical codes.

⚠ WARNING: Do not connect service wiring until you have read and fully understand the pages in this document titled “Service Wiring.” If you are uncertain about the type of power available at the service panel, consult your local utility, or contact Tesla for assistance.

1 Turn off the power.

⚠ WARNING: RISK OF ELECTRIC SHOCK! Before connecting the wiring, use a voltmeter to confirm that NO POWER is available at the service wiring or terminals.

2 Pull the service wiring into the High Power Wall Connector. If using a hub, connect conduit to the hub before connecting it to the enclosure.

3 Strip the three wires 3/8” (10 mm).

4 Connect wiring to the terminal block. Connect L1 to black, L2/N to red, and green ground to one of the two available ground connectors, as shown.

NOTE: The maximum size of the ground wire is 4 AWG. Also note that neutral is not used by the High Power Wall Connector. To ensure proper operation, verify that neutral is connected to earth ground inside the circuit breaker box or the main electrical panel.

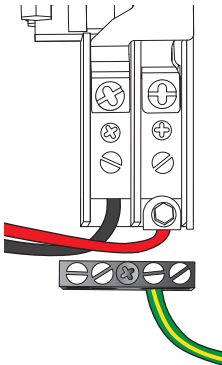

5 Tighten the L1 and L2 screws to 35-50 in-lbs, depending on wire gauge. Tighten the ground screw as follows:

Wire Gauge AWG CU-AL	Torque (in-lbs)
14-10 CU 12-10 AL	20
8	25
6-4	35
Two 14 or 12 CU Two 12 or 10 AL	25



Step Six - Confirm a Successful Installation

- 1 Set the DIP switches, located in the lower right-hand portion of the connector, to the test setting shown here. Use a pointed non-conductive object such as a pen.

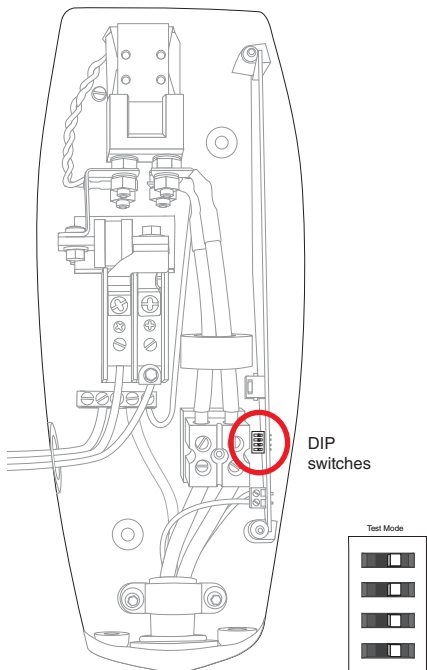

- 2 While holding the front cover near the connector, re-connect the ribbon cable.

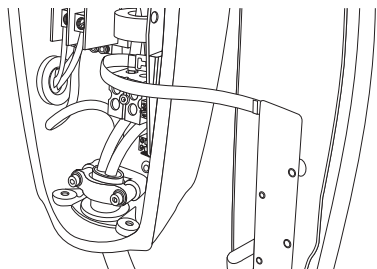

- 3 Hang the front cover over the hinge located at the top of the connector. Do not secure the front cover yet.

- 4 Turn on the power.
- 5 Hold the RESET button for five seconds. This button is located on the lower right side of the High Power Wall Connector.



You should hear the contacts close and see the High Power Wall Connector's lights sequentially illuminate green.

If the RED error light illuminates or flashes, see the Troubleshooting table on page 18 and resolve the error before continuing.

If the RED error light is not illuminated or flashing, continue with the next two steps.



- 1 Turn off the power.



WARNING: RISK OF ELECTRIC SHOCK! Before continuing, use a voltmeter to confirm that NO POWER is available at the service wiring or terminals.

- 2 Open the front cover and hold it with one hand while completing the next step.



CAUTION: Do not release the front cover and allow it to hang from the ribbon cable. Doing so can damage the ribbon cable's connectors.

- 3 Adjust the DIP switches to set the operating current based on the type of breaker being used (see page 7). Use a pointed non-conductive object such as a plastic pen.

NOTE: Power MUST be turned off before setting or changing DIP switches. If you set DIP switches with the power on, not only is it dangerous because of the risk of electric shock (see warning above), but the changes are not recognized.

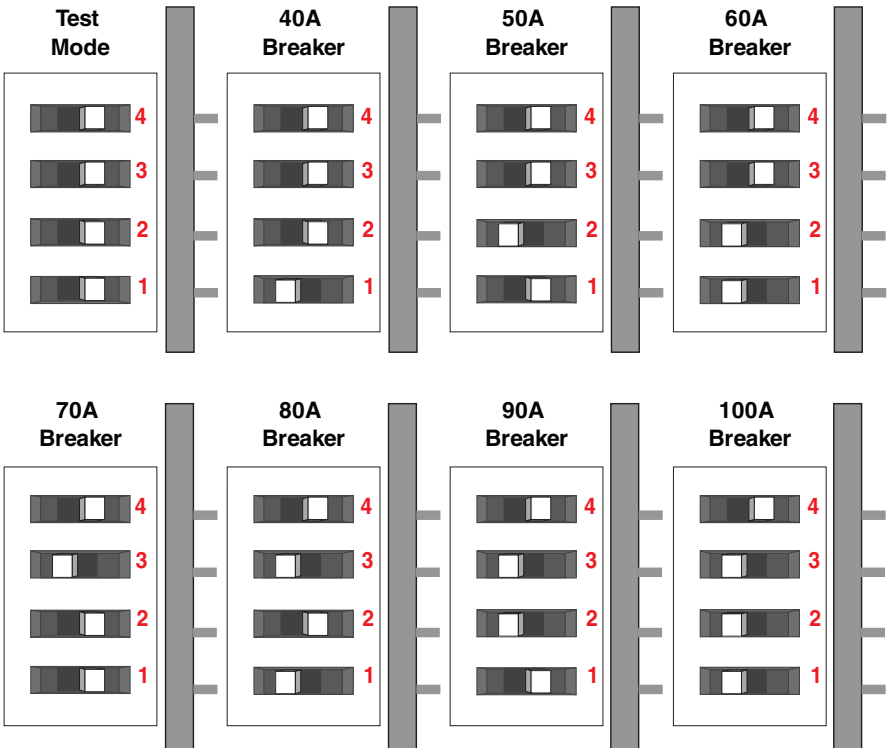



Step Eight - Secure Cover and Power Up

- 1** Reposition the front cover over the unit, aligning the five tabs on the back of the front cover with their corresponding slots. Starting at the bottom and working upwards, press firmly on both sides of the front cover until it clicks into place.
- 2** Using a T20 torx driver, re-attach the two security screws that you removed from the bottom of the High Power Wall Connector in “Step Two - Install Wall Bracket” on page 10.
- 3** Turn on the power.
- 4** Attempt to charge the car to ensure the High Power Wall Connector is operating correctly and charging at the selected operating current. For instructions on how to charge, refer to the owner information provided with your vehicle.



- 1 Use the Cable Organizer's bracket as a guide to mark the location on the wall for the two mounting screws.

NOTE: The height of the bracket should ensure that the charging connector is located at a maximum of 48" from floor level.* The minimum height is 18" (46 cm) if mounting indoors, and 24" (61 cm) if mounting outdoors.

 *CAUTION: If installing in a public location, consider laws and regulations that accommodate persons with disabilities (for example, the American with Disabilities Act).

- 2 Drill two 3/16" (4.8 mm) holes in the wall.
- 3 Insert the two Poly-Set anchors into the holes until their flanges are flush.
- 4 Use the supplied Phillips screws and washers to secure the bracket to the wall.

To ensure the screws are secure, apply additional turns after the screw head is against the bracket:

Drywall Thickness	Number of Additional Turns
3/8"	7-9
1/2"	5-7
5/8"	3-4
3/4"	1-2

NOTE: For more details on using the anchors and screws, refer to the Poly-Set Installation Instructions, included in the shipping box.

- 5 Slide the Cable Organizer onto the bracket as shown. If desired, you can insert the High Power Wall Connector's cable into the groove between the bracket and the Cable Organizer, as shown.

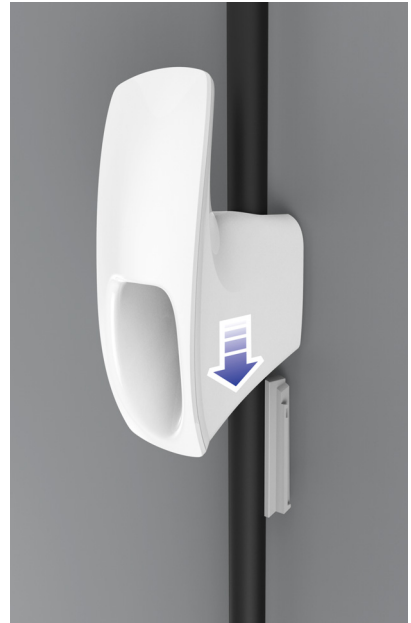



Observe the lights on the front of the High Power Wall Connector, then use the following table to resolve a fault.

Green Lights	Red Light	What It Means	What To Do
Top light on	Off	Power on. High Power Wall Connector is powered, but not charging.	Make sure the High Power Wall Connector is plugged into the car.
Off	1 flash	Ground fault. Electrical current is leaking through a potentially unsafe path.	This should automatically reset in 15 minutes. If not, make sure nobody is touching the car, then press the RESET button.
Off	2 flashes	The High Power Wall Connector did not pass its internal self check.	Unplug the High Power Wall Connector from the car and press the RESET button. Plug the High Power Wall Connector back into the car. If the error persists, unplug the High Power Wall Connector from the car, power off the High Power Wall Connector, then power it back on again before plugging it back into the car.
Off	3 flashes	Contactors failed.	Unplug the High Power Wall Connector from the car and wait 10 seconds. If the error persists, contact Tesla.
Off	4 flashes	Ground lost.	Make sure the power outlet is properly grounded. Make sure the hot and neutral pins are wired properly. If uncertain, ask your electrician.
Off	5 flashes or more	The High Power Wall Connector requires servicing.	Contact Tesla.

QUESTIONS?

Contact Tesla at 1-877-79-TESLA.



Always ensure that after charging, the charging cable is returned to the Cable Organizer and the charging connector is clear of the floor.

Regularly inspect the High Power Wall Connector and charging cable for signs of damage. If damage is found, contact Tesla.

The High Power Wall Connector contains no user-serviceable components. If the unit is not operating correctly, contact Tesla.

Wipe the outside of the High Power Wall Connector, the charging cable, and the connector end of the charging cable with a clean dry cloth to remove any accumulation of dust and dirt.



WARNING: Turn off input power at the circuit breaker before cleaning the High Power Wall Connector.



WARNING: Do not use cleaning solvents, scouring powder, or any type of abrasive pad to clean the High Power Wall Connector, its charging cable, or the vehicle's charging port.



CAUTION: To reduce the risk of electrical shock or equipment damage, do not allow liquid to enter the High Power Wall Connector while cleaning it.



Connector Limited Warranty

GENERAL TERMS

Subject to the exclusions and limitations described below, the Connector Limited Warranty covers the repair or replacement necessary to correct any manufacturing defects in the factory-supplied High Power Wall Connector that occurs under normal use for a period of 12 months from the date of invoice to the customer.

This Connector Limited Warranty does not cover any damage or malfunction directly or indirectly caused by, due to, or resulting from, normal wear or deterioration, abuse, misuse, negligence, accident, lack of or improper installation, use, maintenance, storage, or transport, including, but not limited to, any of the following:

- Failure to follow the instructions, maintenance, and warnings in this document;
- External factors including but not limited to objects striking the High Power Wall Connector, faulty and damaged power outlets, the environment, or an act of God, including, but not limited to, fire, earthquake, water, lightning, and other environmental conditions;
- General appearance or damage to paint, including chips, scratches, dents, and cracks;
- Failure to contact Tesla upon discovery of a defect covered by this Connector Limited Warranty;
- Use of faulty power receptacles;
- Any repair, alteration, or modification of the High Power Wall Connector or any part, or the installation or use of any parts or accessories, made by a person or facility not authorized or certified to do so;
- Lack of or improper repair or maintenance, including use of non-genuine Tesla accessories or parts; and
- Use for commercial purposes.

Although Tesla does not require you to perform all maintenance, service, or repairs at a Tesla Service Center or Tesla authorized repair facility, this Connector Limited Warranty may be voided or coverage may be excluded due to lack of or improper maintenance, service or repairs. Tesla Service Centers and Tesla authorized repair facilities have special

training, expertise, tools, and supplies with respect to the High Power Wall Connector and, in certain cases, may employ the only persons or be the only facilities authorized or certified to work on the High Power Wall Connector. Tesla strongly recommends that you have all maintenance, service, and repairs done at a Tesla Service Center or Tesla authorized repair facility in order to avoid voiding, or having coverage excluded under, this Connector Limited Warranty.

LIMITS OF LIABILITY

Implied and express warranties and conditions arising under applicable state or provincial laws or federal statute or otherwise in law or in equity, if any, including, but not limited to, implied warranties and conditions of merchantability or merchantable quality, fitness for a particular purpose, durability, or those arising by a course of dealing or usage of trade, are disclaimed to the fullest extent allowable by law, or limited in duration to the term of this Connector Limited Warranty. The performance of necessary repairs and parts replacement is the exclusive remedy under this Connector Limited Warranty or any implied warranties. Liability is limited to the reasonable price for repair or replacement of the High Power Wall Connector, not to exceed the manufacturer's suggested retail price. Replacement may be made with parts of like kind and quality, including non-original manufacturer's parts or remanufactured parts, as necessary.

In no event shall liability for any defect under this Connector Limited Warranty exceed the fair market value of the High Power Wall Connector at the time immediately preceding the discovery of the defect. In addition, the sum of all benefits payable under this Connector Limited Warranty shall not exceed the price you paid for the High Power Wall Connector.

Tesla does not authorize any person or entity to create for it any other obligations or liability in connection with this Connector Limited Warranty. The decision of whether to repair or replace a part or to use a new or remanufactured part will be made by Tesla, in its sole discretion.



Tesla hereby disclaims any and all indirect, incidental, special, and consequential damages arising out of or relating to the High Power Wall Connector, including, but not limited to, transportation to and from a Tesla Authorized Service Center, loss of High Power Wall Connector or vehicle value, loss of time, loss of income, loss of use, loss of personal or commercial property, inconvenience or aggravation, emotional distress or harm, commercial loss (including but not limited to lost profits or earnings), towing charges, bus fares, vehicle rental, service call charges, gasoline expenses, lodging expenses, damage to tow vehicle, and incidental charges such as telephone calls, facsimile transmissions, and mailing expenses.

The above limitations and exclusions shall apply whether your claim is in contract, tort (including negligence and gross negligence), breach of warranty or condition, misrepresentation (whether negligent or otherwise), or otherwise at law or in equity, even if Tesla is advised of the possibility of such damages or such damages are reasonably foreseeable.

WARRANTY ENFORCEMENT LAWS AND DISPUTE RESOLUTION

To the fullest extent allowed by the law of your jurisdiction, Tesla requires that you first provide Tesla, during the applicable warranty period specified in this Connector Limited Warranty, with written notification of any defects you have experienced, within a reasonable time to allow Tesla an opportunity to make any needed repairs, and to submit to our dispute settlement program before you pursue any remedy under these laws. Please send your written notification to:

Tesla Motors, Inc.
3500 Deer Creek Road
Palo Alto, California 94304
Attention: Vehicle Service

Please include the following information:

- High Power Wall Connector and Invoice Date.
- Your name and contact information.
- Name and location of the Tesla Store and/or Tesla Service Center nearest you.

- Description of the defect.
- History of the attempts you have made with Tesla to resolve the concern, or of any repairs or services that were not performed by Tesla.

In the event that any disputes, differences, or controversies arise between you and Tesla related to this Connector Limited Warranty, Tesla will explore all possibilities for an amicable settlement. In case an amicable settlement is not reached, Tesla offers a dispute settlement program through:

NATIONAL CENTER FOR DISPUTE
SETTLEMENT ("NCDS")
P.O. Box 526
Mt. Clemens, MI 48046
1-866-629-3204

Tesla requires that you submit your dispute to our dispute settlement program and wait for a decision to be issued prior to pursuing any remedy under federal or state laws (including 15 U.S.C. Section 2310 or California Civil Code Section 1793.22(b)), although you may be entitled to pursue a remedy without submitting under certain state laws or if you pursue any rights or remedies not created by these laws. This dispute settlement program administered by NCDS is free of charge to you and is conducted by local NCDS professionals who are trained and experienced in mediation and arbitration.

NCDS resolves disputes involving this Connector Limited Warranty which arise during the applicable warranty period specified in this Connector Limited Warranty. You must file a request for arbitration with NCDS within 60 days (or 6 months in certain jurisdictions) of the expiration of the applicable warranty period, provided you sent written notice to Tesla, as specified above, of the alleged defect during the applicable warranty period.



To initiate arbitration, you must contact NCDS at 1-866-629-3204 or P.O. Box 526, Mt. Clemens, MI 48046, complete an NCDS customer claim form, and mail it to NCDS. Please also provide a copy of your written notification sent to Tesla and/or all information required in such notification specified above, your desired resolution, and all receipts if requesting reimbursement. Upon receipt of your request, NCDS will contact you regarding the status of your case and provide you with additional details about the program.

When NCDS receives your request, it will be forwarded to Tesla for response. After analyzing all information pertaining to your case, NCDS will schedule a technical evaluation if applicable. If you request it, an oral hearing will be held prior to a decision being rendered. At this hearing, all evidence is admissible. After considering all testimony and documents, the arbitrator will review the applicable legal standards and render a decision. A settlement satisfactory to all parties may be negotiated at any time, including prior to or after the arbitrator's decision.

NCDS's decision is binding on Tesla but not on you. If you accept NCDS's decision, Tesla will comply with the decision in a reasonable time not to exceed 30 days after Tesla receives notice of your acceptance. Remedies include, but are not limited to, repairs; reimbursement for repairs and incidental expenses, such as transporting costs; and repurchase or replacement of the High Power Wall Connector. NCDS decisions do not include attorney fees or punitive, multiple, or consequential damages, except incidental damages as required by applicable law. NCDS findings and decisions are admissible as evidence in any legal proceedings concerning the High Power Wall Connector.

The description provided above is only a brief summary of the dispute settlement program administered by NCDS. The dispute settlement program may be changed at any time without prior notice. Contact NCDS at the above listed address or phone number for the most current information concerning the dispute settlement program.

TESLA

3500 Deer Creek Road
Palo Alto, CA 94304